

LFT-503AG Website Specification

编辑:LJJ 审核: Bill 版本:A0 Date:20260318

FRONT VIEW

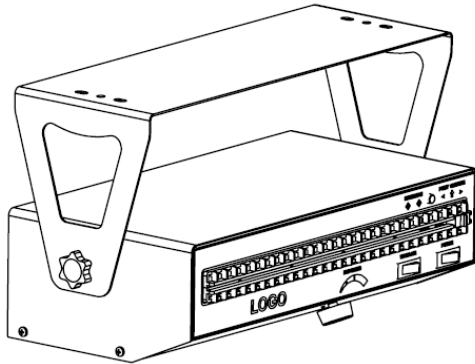

BACK VIEW

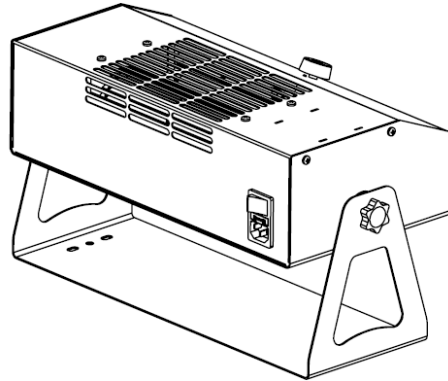

1. Parameters:

产品型号 Model number:	LFT-503AG
功能 Function:	Mechanical switch, adjustable fan, optional hot air, ION
传感器 Sensor:	N/A
控制界面 LCD / APP/WIFI:	N/A
输入电压 Input voltage:	110-120V/60Hz or 220-240V/50Hz
功率 Power:	350W
离子平衡度 Ion balance:	1V±10V
出风量 Air flow:	Max 190CFM
离子产量 Negative ion production:	≥5 x 10 ⁶ cm ³ (or≥2.5 x 10 ⁶ /cm ³)
气流面积 Airflow area:	60cmX120cm
噪音 Noise:	45dB
冷却方式 Cooling method:	Air-cooled
气源 Air source:	Air
净重 Net weight:	?kg
毛重 Gross weight:	?kg
产品尺寸 Product size:	L410XW213XH225 mm
包装尺寸 Packing size:	? mm (1PCS/BOX)
工作环境温度 Working Temp:	-10℃~+55℃
存放环境温度 Storage Temp:	-20℃~+60℃
工作环境湿度 Working humidity:	10%~90% , 95°F (35℃)