

LFT-151NO Website Specification

编辑:LJJ 审核: Bill 版本:A0 Date:20260318

FRONT VIEW

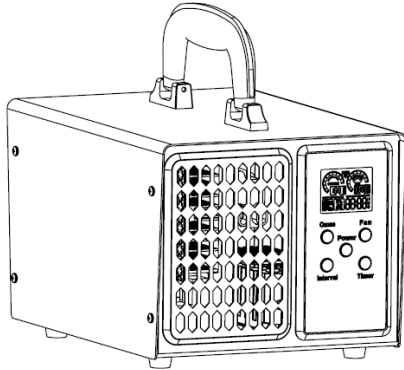

BACK VIEW

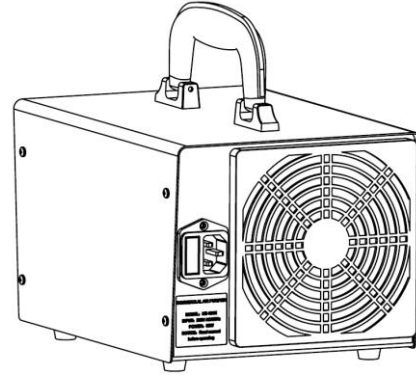

1. Parameters:

产品型号 Model number:	LFT-153NO/NG/NK
功能 Function:	LCD display, 5 adjustable ozone levels, 5 adjustable fan speeds, intelligent
定时器 Timer:	timer, optional 12H or 24H circulation
控制界面 LCD / APP/WIFI:	LCD
输入电压 Input voltage:	110-120V/60Hz or 220-240V/50Hz
功率 Power:	80W
陶瓷片尺寸 Ozone plate size:	90X70 mm 1pc (Fixed)
出风量 Air flow:	Max 106CFM
臭氧产量 Ozone production:	7000mg/h
适用面积 Applicable area:	200M ² or 2000FT ²
噪音 Noise:	45 dB
冷却方式 Cooling method:	Air-cooled
气源 Air source:	Air
净重 Net weight:	2.6kg
毛重 Gross weight:	3.3kg
产品尺寸 Product size:	L238XW170XH153 mm
包装尺寸 Packing size:	305X240X235 mm (1PCS/BOX)
工作环境温度 Working Temp:	-10°C~+50°C
存放环境温度 Storage Temp:	-20°C~+60°C
工作环境湿度 Working humidity:	10%~90% , 95°F (35°C)